

# ORANGE PEEL GRABS

**PRODEM ORANGE PEEL GRABS ARE AVAILABLE IN A NUMBER OF DIFFERENT STYLES. THE MT SERIES OFFERS ULTIMATE POWER AND RELIABILITY WITH SLEW RING/MOTOR PROTECTION, EASY ACCESS TO HYDRAULIC CYLINDERS VIA PROTECTION COVER.**

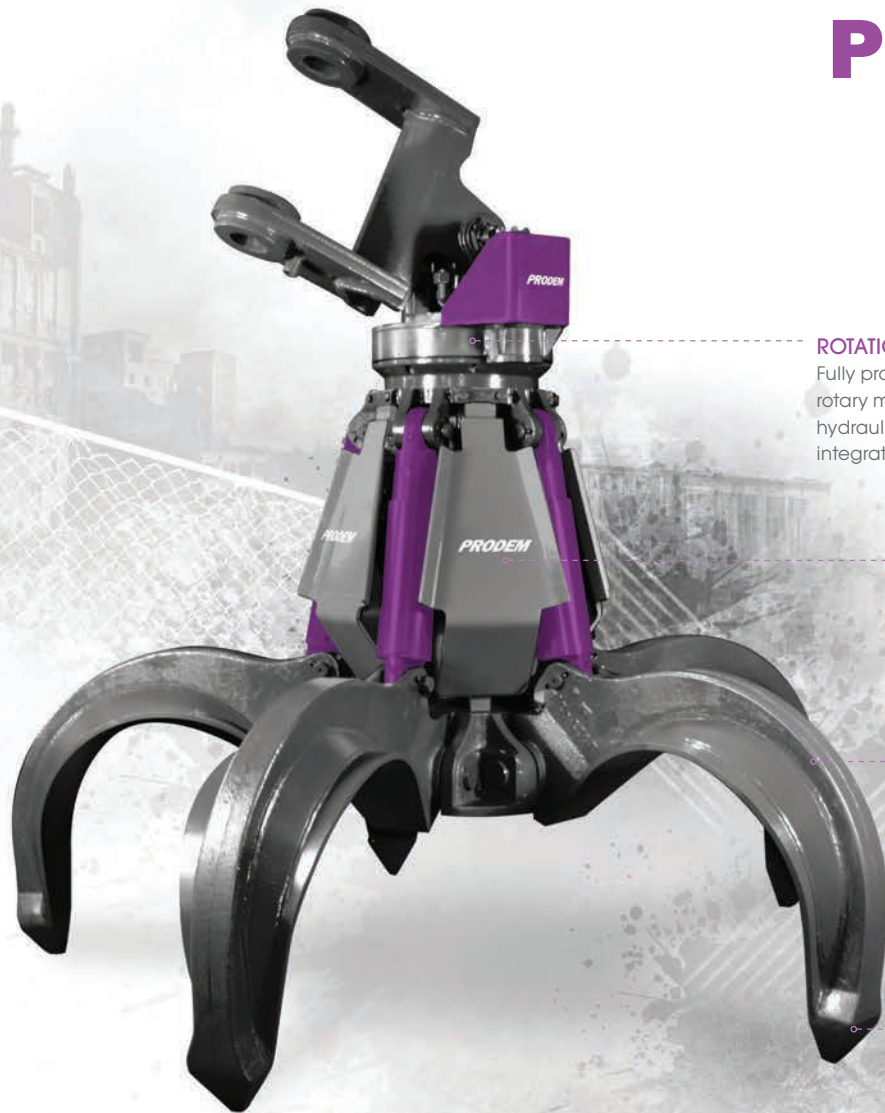

#### ROTATION MOTOR

Fully protected compact rotary motor, endless hydraulic rotation with integrated pressure limitation

#### CYLINDER PROTECTION

Full cylinder over-stroke protection

#### SHELLS

Made from high-strength fine-grain steel, three, four and five shell versions available

#### TIPS

Forged manganese-replaceable

#### BENEFITS OF PRODEM ORANGE PEEL GRABS

##### TIPS

- >> Forged manganese-replaceable.

##### CYLINDER PROTECTION

- >> Full cylinder over-stroke protection.

##### ROTATION MOTOR

- >> Fully protected compact rotary motor, endless hydraulic rotation with integrated pressure limitation.

##### SHELLS

- >> Made from high-strength fine-grain steel, three, four and five shell versions available.

##### HOSE PROTECTION SHIELD

TECHNICAL SPECIFICATION

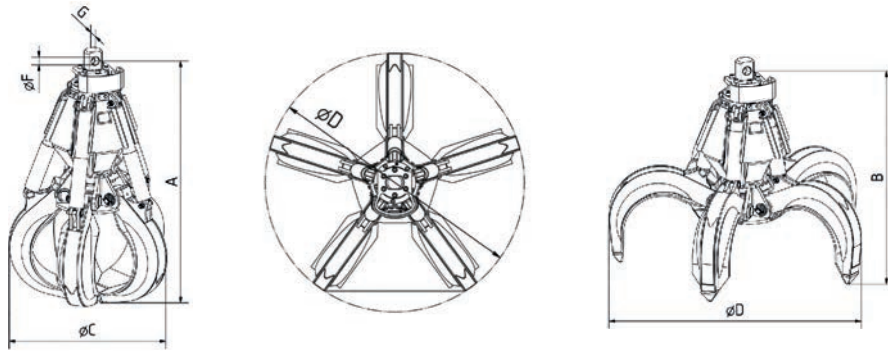

>> The PRODEM Orange Peel Grab range offers grabs from a 300-1250 litre volume to suit every need.

**“ WE’VE FOUND THE PRODEM SCRAP GRABS TO BE VERY RELIABLE, PARTICULARLY WITH THEIR SLEW RING SYSTEM. THEY ARE BUILT TO A VERY HIGH LEVEL OF QUALITY AND OFFER GREAT PERFORMANCE AND RELIABILITY.”**

Model	Excavator Weight Class (t)	Max. Grab Capacity (t)	Max. Rotation Load (t)	Working Pressure - Rotation (bar)	Working Pressure - Open/Close (bar)	Max. Flow - Rotation (l/min)	Max. Flow - Open/Close (l/min)
MT3.5	16-20	4	15	140	300	35	90
MT3.5/MH	19-23	4	15	140	300	35	90
MT4.5	20-30	8	15	140	350	35	115
MT4.5/MH	22-40	8	15	140	350	35	115
MT5.5	30-45	10	20	140	300	30	90
MT5.5/MH	40-70	10	20	140	300	30	90

Model	Capacity (l)	Weight (kg)	Diameter (mm) (Open)	Height A (mm) (Closed)	Height B (mm) (Open)	Width C (mm) (Closed)	Width D (mm) (Open)	Rotating Connector Width G (mm)	Mounting Pin Diameter F (mm)
MT3.5-300	300	1405	1930	2140	1760	1250	2100	114	70
MT3.5-400	400	1450	2065	2210	1785	1310	2250	114	70
MT3.5-600	600	1480	2230	2335	1845	1390	2430	114	70
MT4.5-400	400	1730	1930	2190	1830	1340	2100	114	70
MT4.5-600	600	1805	2160	2315	1775	1450	2340	114	70
MT4.5-800	800	1940	2435	2485	1930	1510	2650	114	70
MT4.5-1000	1000	1980	2620	2590	1970	1630	2860	114	70
MT4.5-1250	1250	2010	2805	2700	2000	1710	3060	114	70
MT5.5-600	600	2245	2240	2395	2030	1530	2440	149	80
MT5.5-800	800	2315	2425	2490	2070	1590	2640	149	80
MT5.51000	1000	2400	2600	2610	2100	1660	2840	149	80
MT5.5-1250	1250	2515	2890	2750	2150	1880	3150	149	80

\* Grab design can be amended to suit customers requirements. \* Larger models available upon request.